

**CONTINUOUS FLUE-GAS ANALYZING SYSTEM  
AIM 50000**

**AIM 50000 P  
CONTINUOUS FLUE-GAS MONITORING SYSTEM**

The AIM 50000 is a state-of-the-art continuous flue-gas monitoring system, and is designed for a wide variety of flue-gas monitoring applications.

The AIM 50000 is a stand-alone analyzer that works automatically. The rugged wall mounted enclosure meets NEMA type 4X (IP65) standards, Optional 19" Rack Mount Type.

The modular approach of the AIM 50000 allows one or more gases (up to 8) to be measured simultaneously. The AIM 50000 uses the latest sensor technology from electro-chemical sensors up to NDIR benches.

The system can analyze samples taken from up to 4 different sampling points. This sequential measurement is only possible with the addition of multiple gas sampling and conditioning devices (AIM 400).

The AIM 50000 offers various outputs such as a serial interface (RS232/RS485), an analog output (volt / current) and an alarm (relay).

All of the above features allow the AIM 50000 to be configured for a variety of applications and can easily be upgraded in the future.



FEATURES	APPLICATIONS
<ul style="list-style-type: none"> <li>● Up to eight different controllers</li> <li>● Up to 4 different sampling points</li> <li>● Analog output (volt/current)</li> <li>● Alarm output</li> <li>● RS232/RS485 digital output</li> <li>● Built to customer specifications</li> <li>● Rugged and weather-resistant</li> <li>● Large display</li> <li>● Easy to use and easy to service</li> <li>● Latest sensor technology</li> </ul>	<ul style="list-style-type: none"> <li>● Boiler / Burner</li> <li>● Turbines</li> <li>● Engines</li> <li>● Incinerators</li> <li>● Process control</li> <li>● Landfills</li> <li>● Cogeneration plants</li> </ul>

**AIM 50000 - APPLICATION EXAMPLE**

One of our most popular systems is the AIM 50000 in combination with the AIM 400. The AIM 400 is a gas conditioning system that cleans and dries the flue-gas.

*Function diagram*

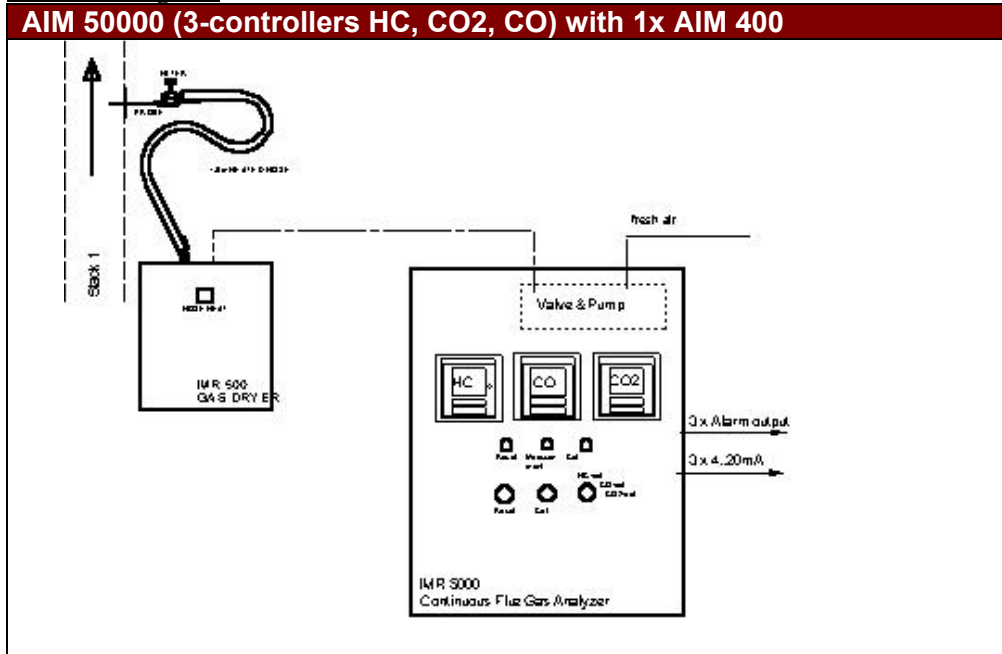

The AIM 400 is equipped with a flange-mounted, gas-sampling probe and a heated hose. Either a 'peltier cooler' or a 'permeation dryer' is used to dry the flue-gas. The conditioned flue-gas is then analyzed by the AIM 50000. Individual sensors (NDIR) are used to analyze HC, CO and CO2. The alarm outputs and analog outputs can be configured individually and are fully scalable across the measurement range.

More examples:

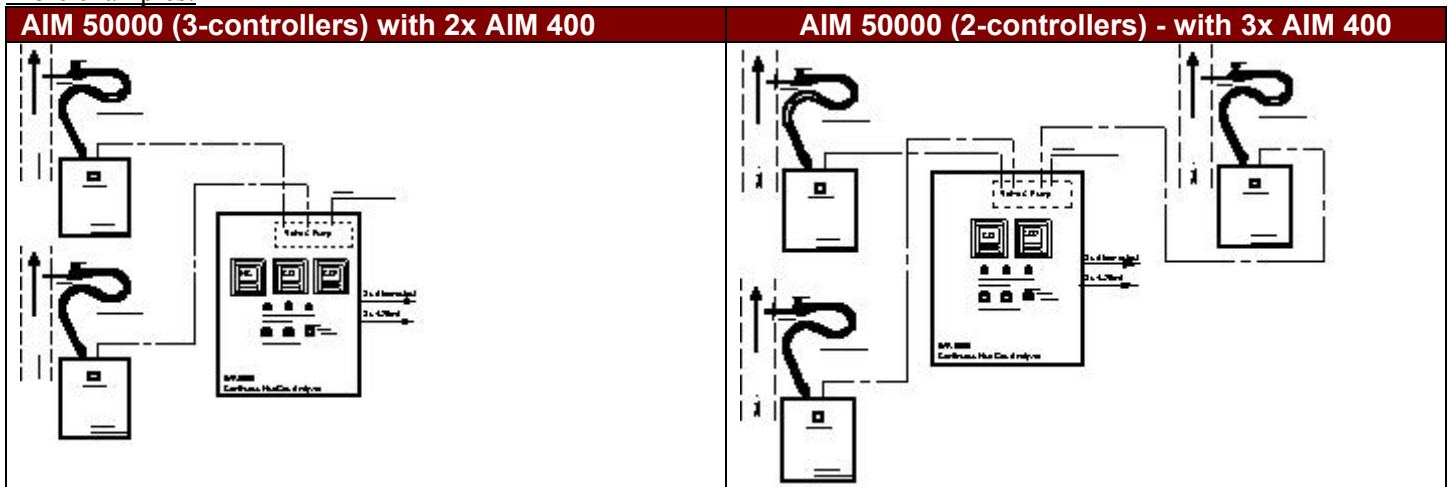

The AIM 50000 is a versatile instrument that can be customized for the customers specific needs. The flue-gas analyzing system can be equipped with up to 8 different controller systems and can measure up to different 4 stacks.

*Block diagram*

**AIM 50000 (3-controllers) with 1x AIM 400**

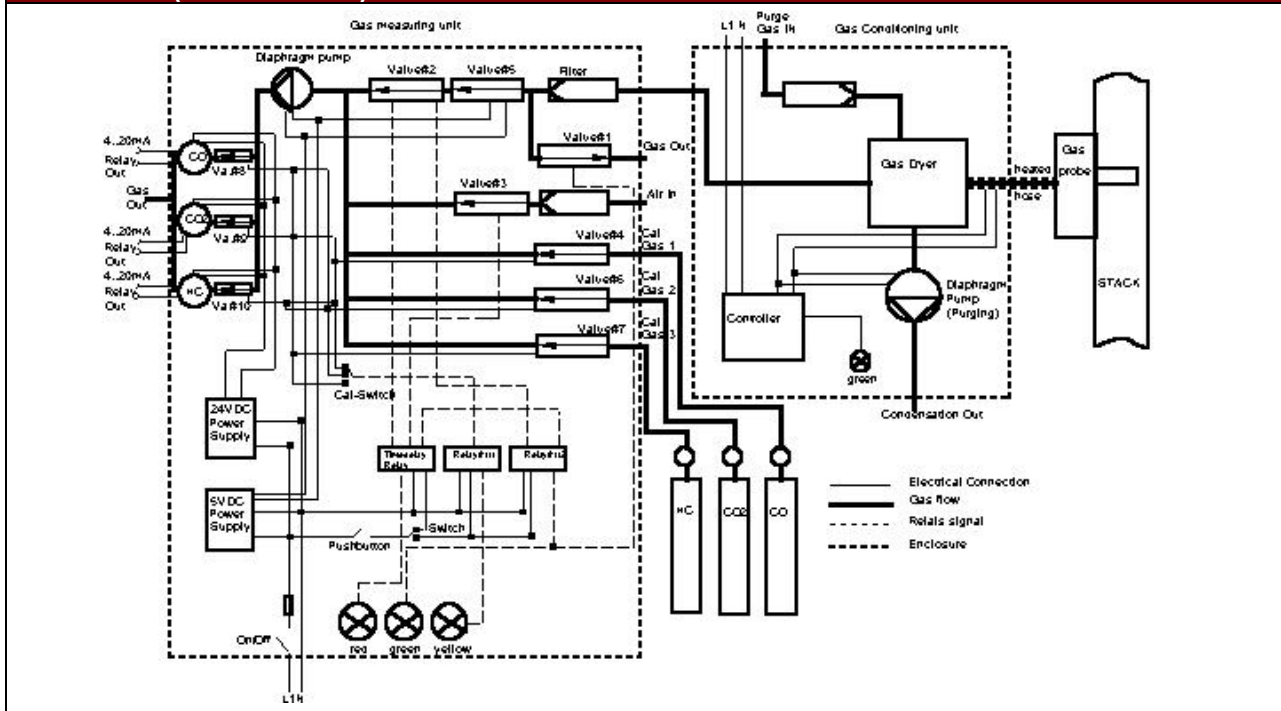

The AIM 50000 is equipped with various solenoids and relays. These components make sure that the unit operates automatically. The calibration of the unit is quite simple. Each controller gets adjusted individually by applying a test gas on the specific calibration fitting.

**AIM 50000 - DISPLAY**



Green



Amber



Red

Each controller has its own display. The height of the LED is 0.83" (21mm) and the color is programmable at any set point (red, green and amber).

**AIM 50000 - OUTPUT FORMATS**

Analog output

Each controller has one individual analog output and each output maybe configured from the display at any time. The outputs are fully scalable across the measurement range.

Format: 0..20mA / 4..20mA / 0-1VDC / 0-10VDC

Alarms (Relay)

Each controller has one individual relay (SPDT). Each relay and its different modes and levels of activation can be configured from the display at any time.

Operation: Absolute/deviation, latched/unlatched, normally open/normally closed, above/below, high/low, band

## PROCESS CONTROLLERS WITH SENSORS / TRANSMITTERS

Any ranges can be specified between the minimum and maximum ranges stated below.

In general any eight channels can be fitted to the system.

Other sensors, measurement ranges and limitations regarding combinations are available upon request.

PARAMETER	PRINCIPLE	PART-NO.	RANGES
O2 Oxygen	Electro-chemical	50050	0-25% to 0-100%
O3 Ozone	Electro-chemical	50075	0-2 to 0-100ppm
CO Carbon monoxide	Electro-chemical	50110	0-500ppm to 0-9,999ppm 0-1% to 0-10%
CO Carbon monoxide	NDIR	50100	0-5% to 0-10%
CO2 Carbon dioxide	NDIR	50150	0-2,000ppm to 0-100%
CH4 Methane	NDIR	50850	0-9,999ppm to 0-30%
HC Hydrocarbons	NDIR	50800	0-9,999ppm to 0-30%
HC Hydrocarbons	Pellistor	50810	0-100%LEL
NO Nitric oxide	Electro-chemical	50200	0-1,000ppm to 0-5,000ppm
NO2 Nitrogen dioxide	Electro-chemical	50500	0-100ppm to 0-500ppm
SO2 Sulfur dioxide	Electro-chemical	50400	0-2,000ppm to 0-4,000ppm
H2S Hydrogen sulfide	Electro-chemical	50600	0-100ppm to 0-500ppm
HCl Hydrogen chloride	Electro-chemical	50900	0-100ppm to 0-200ppm
H2 Hydrogen	Electro-chemical	50650	0-1,000ppm to 0-2%
Cl2 Chlorine	Electro-chemical	50950	0-20ppm
NH3 Ammonia	Electro-chemical	50925	0-50ppm to 0-200ppm
Flue-gas temperature	Thermocouple type K	50675	0-1,200°C

## AIM 50000 - SPECIFICATION

<b>Display</b>	Each controller; 4-digit, 9-segment LED, 0.83" (21mm) Red, green and amber programmable colors for process variable
<b>Modes</b>	Time and Amplitude proportional control modes; selectable manual or auto PID, proportional with integral
<b>Damping</b>	0000 to 0008
<b>Soak</b>	00.00 to 99.99, or OFF
<b>Ramp to Setpoint</b>	00.00 to 99.99, or OFF
<b>Relay</b>	250VAC or 30VDC @ 3A; configurable for on/off, PID and Ramp and Soak
<b>Output</b>	SPDT type
<b>SSR</b>	20-265VAC @ 0.05-0.5A (resistive load); continuous
<b>DC pulse</b>	Non-isolated; 10VDC @ 20mA
<b>Analog output</b>	Non-isolated; proportional 0 to 10VDC or 0 to 20mA; 500Ohm max
<b>Communications</b>	Optional; RS232 or RS485; 300 to 19.2 K baud
<b>Power supply</b>	120VAC/60Hz or 240VAC/60Hz
<b>Enclosure</b>	Wall mounted, NEMA4X/IP65(Optional 19" Rack Mount Type W19" x H5.25" x D8") Dimensions in inch (mm): 18.3 (465) x 13.8 (350) x 7.9 (200) (up to 2 controllers) 27.6 (700) x 19.7 (500) x 9.8 (250) (up to 4 controllers) 55.1 (1400) x 29.5 (750) x 14.7 (375) ( up to 8 controllers)
<b>Operating temperature</b>	50°F to 104°F (10°C to 40°C)
<b>Storage temperature</b>	-4°F to 122°F (-20°C to 50°C)
<b>Operating environment</b>	90% RH non-condensing

© Copyright 2007 AIM Air Instruments & Measurements, llc.